



INSTALLATION INSTRUCTIONS

Accessory
ATF COOLER
P/N 06255-RN0-315

Application
2014 PILOT
(2WD)

Publications No.
All 50237

Issue Date
AUG 2013

PARTS LIST

ATF Cooler

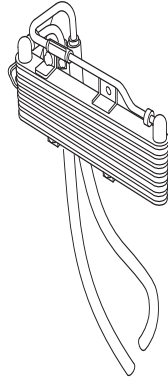

3 Washer-bolts (6 x 12 mm)



2 Hose clamps



Hose spacer (5 A/T)



2 Hose clips



Mirror hang-tag



3 Labels



TOOLS AND SUPPLIES REQUIRED

Phillips screwdriver
Stubby Phillips screwdriver
Ratchet
10 mm Socket
10 mm Open end wrench
Push pin cap pliers (P/N 07AAC-001A100)
Diagonal cutters
Blanket

Illustration of the ATF Cooler in the Vehicle

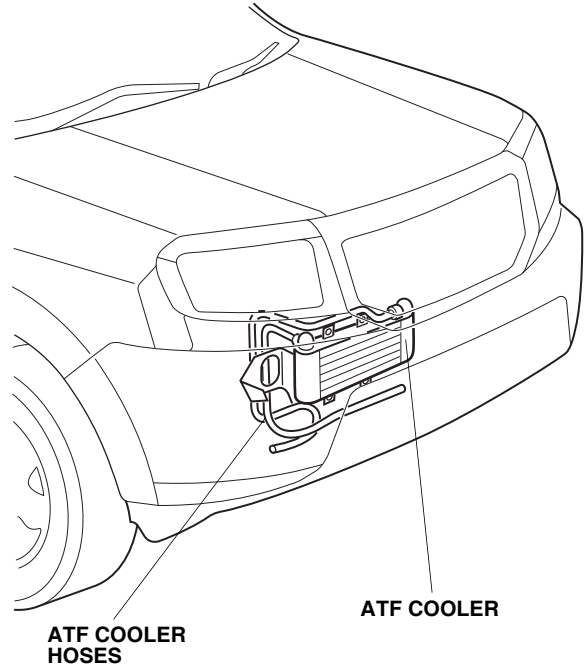

INSTALLATION

Customer Information: The information in this installation instruction is intended for use only by skilled technicians who have the proper tools, equipment, and training to correctly and safely add equipment to your vehicle. These procedures should not be attempted by "do-it-yourselfers."

NOTE:

- Allow the engine and transmission to cool down before installing the ATF cooler.
 - Be careful not to damage the front bumper or other finished surfaces of the body.
1. Make sure you have the anti-theft code for the radio, then write down the radio station presets.
 2. Disconnect the negative cable from the battery.

3. Open the hood, and remove the intake air box (two clips).

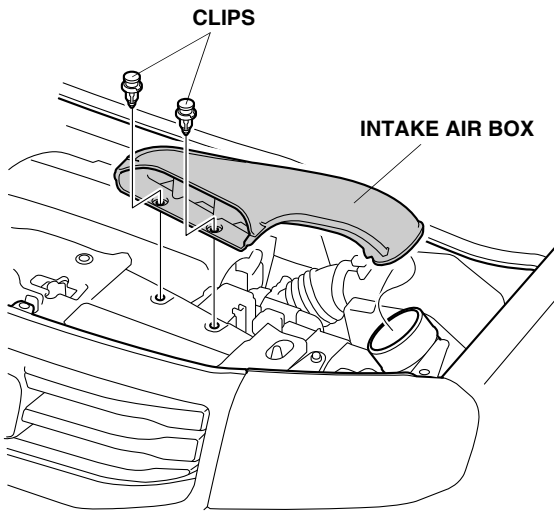

4. Remove the front bulkhead cover (seven clips).

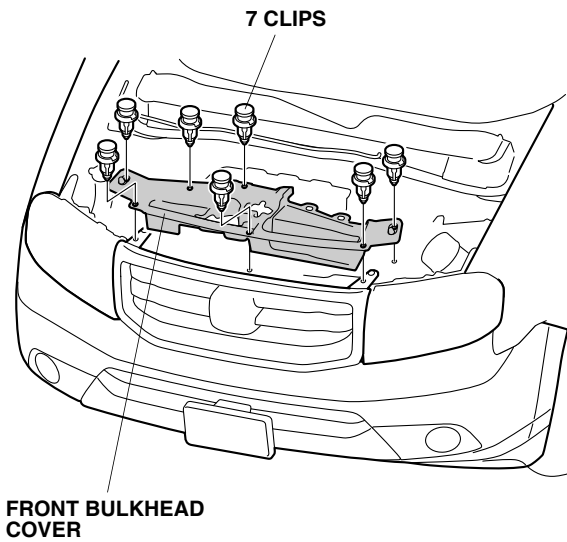

5. Remove the front bumper:

- Along the bottom of the bumper, remove the eight medium clips, three long clips, and the two collared bolts.
- At each fenderwell, remove the two short self-tapping screws, one long self-tapping screw, and the lower washer-bolt (black).
- At the top of the grille, remove the two washer-bolts (silver).
- With the help of an assistant, release the tabs between the headlight and the bumper, unplug the fog light connectors (if equipped), and remove the bumper. Place the front bumper on a blanket after removal.

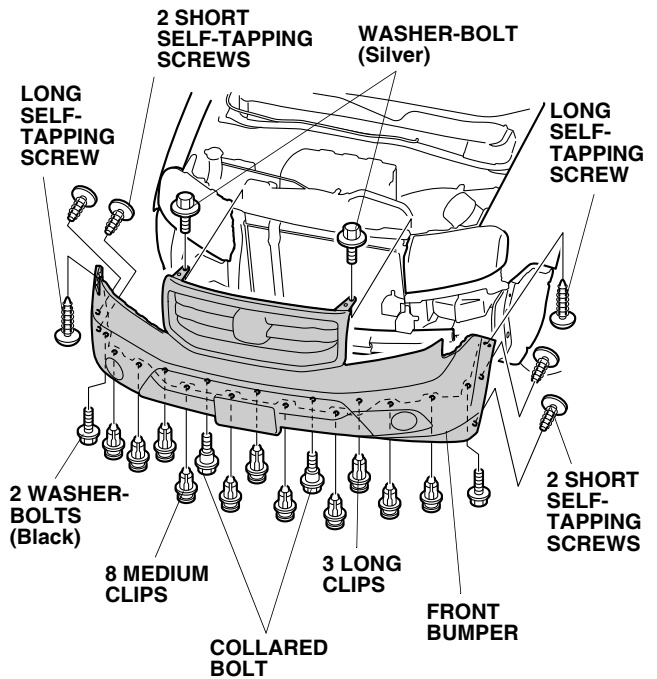

- Remove the splash shield (two bolts and eight clips).

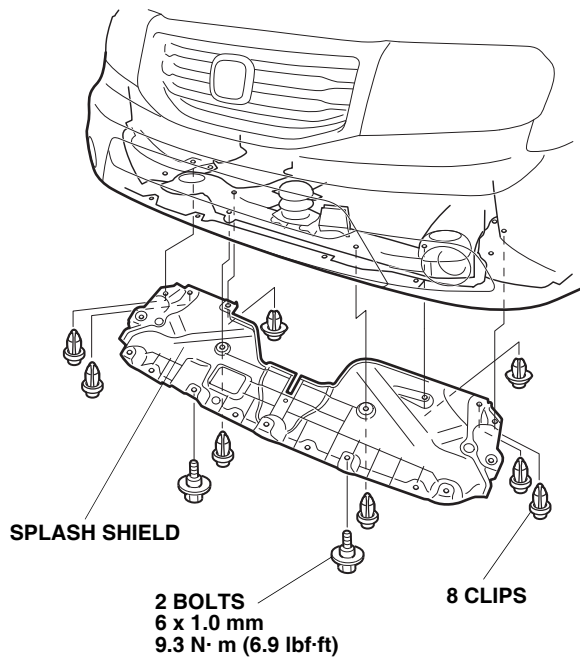

- On the right front bulkhead, remove the clip that secures the power steering reservoir return hose to the bracket.

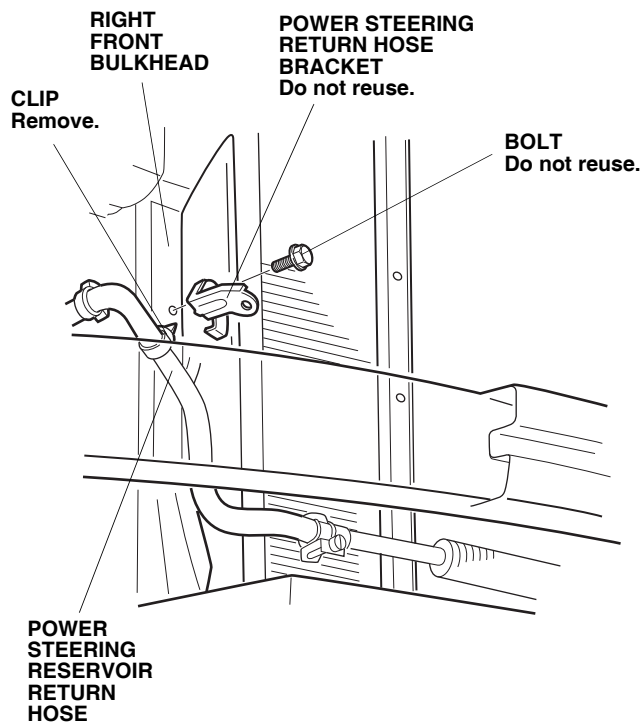

- Remove the power steering return hose bracket (one bolt). The bolt and bracket will not be reused.

Installing the ATF Cooler

- Get the ATF cooler and the three washer bolts. Hold the ATF cooler in place near the right front bulkhead, and route both ATF cooler hoses down between the radiator and the front bulkhead. Install the ATF cooler with the three washer bolts into the threaded holes in the front bulkhead and center support. Tighten the bolts securely.

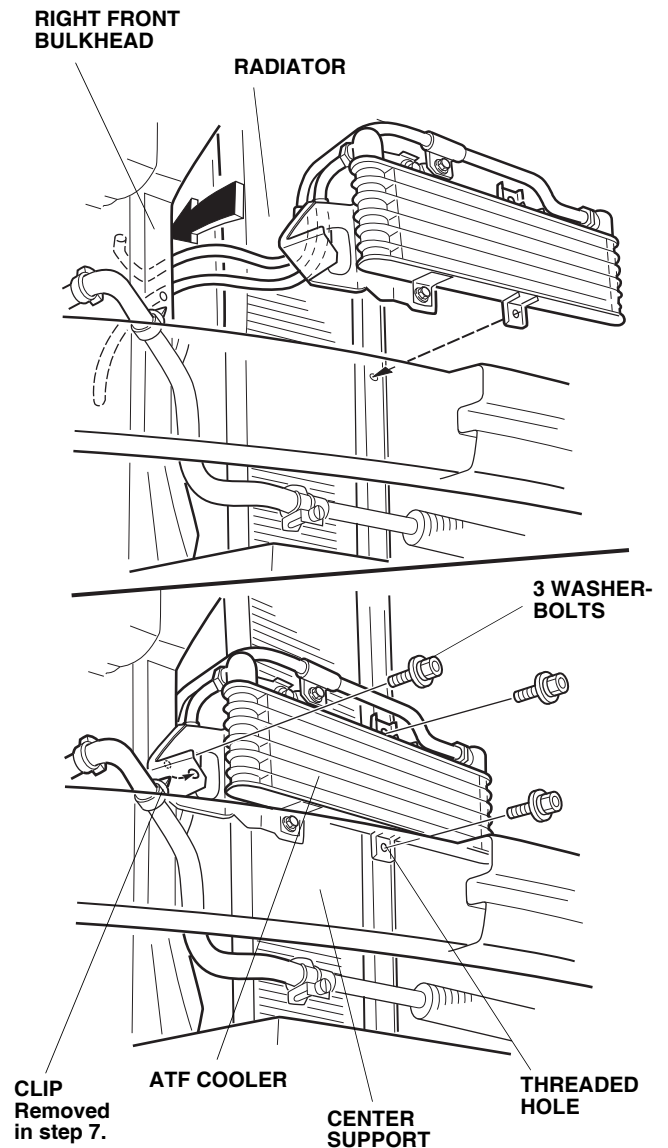

- Install the clip on the power steering reservoir return hose (removed in step 7) into the clip hole in the ATF cooler.

- Under the vehicle behind the radiator, remove the ATF cooler bypass hose from each cooler pipe (the hose and clamps will not be reused). Plug the cooler pipes to prevent ATF from leaking out.

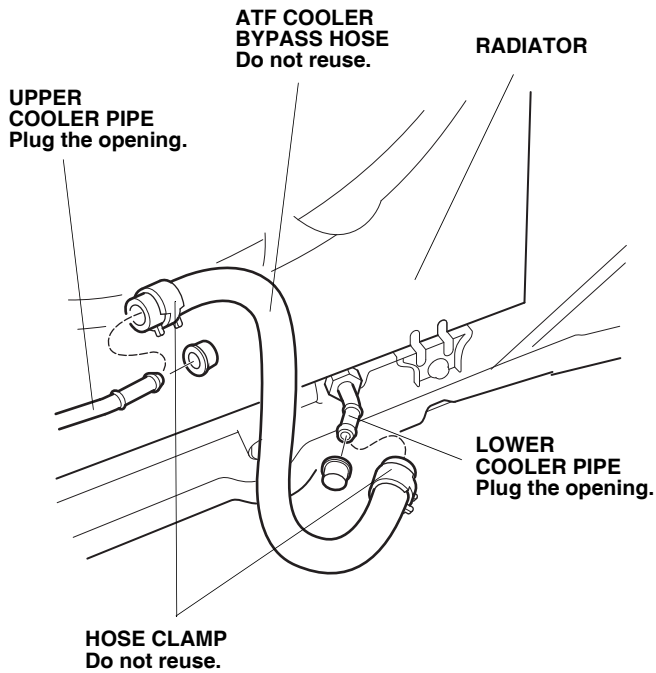

- Remove the plug from the lower cooler pipe, and install the curved (short) hose from the ATF cooler to the lower pipe using one of the supplied hose clamps.

NOTE: When installing the hose clamps, make sure they do not interfere with surrounding parts.

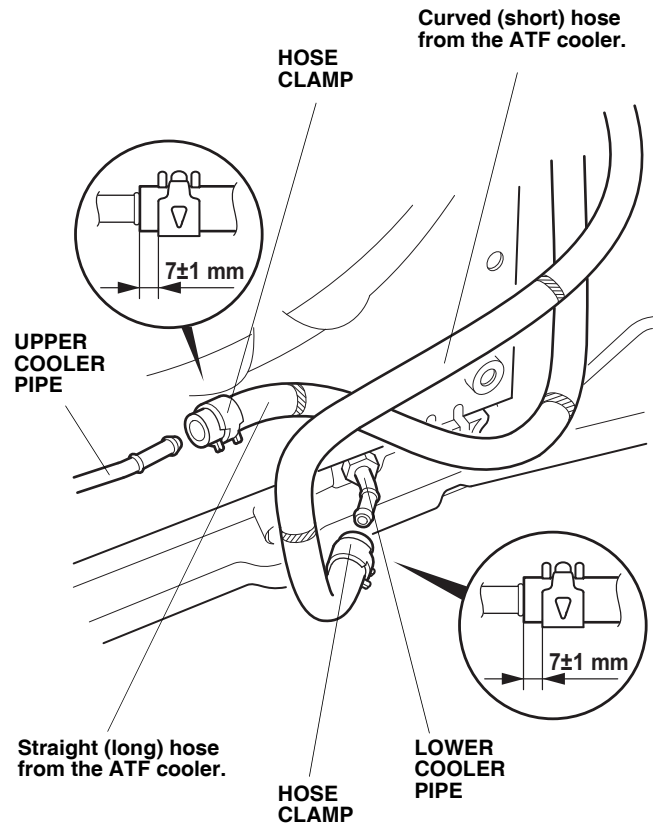

- Remove the plug from the upper cooler pipe, and install the straight (long) hose from the ATF cooler to the upper pipe using the other supplied hose clamp.

- Attach one hose clip to the upper white line on the curved (short) hose from the ATF cooler, then install the clip into the upper hole in the radiator shroud.

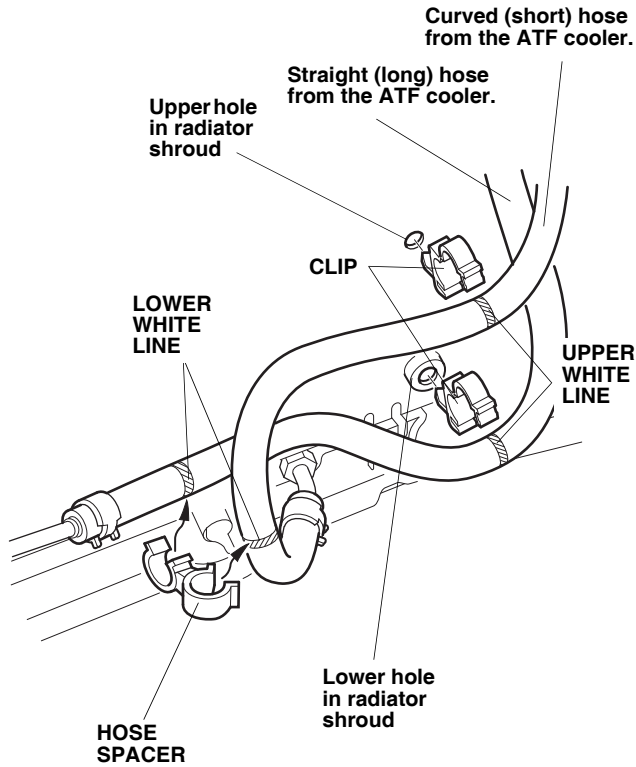

- Attach one hose clip to the upper white line on the straight (long) hose from the ATF cooler, then install the clip into the lower hole in the radiator shroud.
- Get the hose spacer. Attach one end of the hose spacer to the lower white line on the curved (short) hose, then attach the other end to the lower white line on the straight (long) hose.

- With the help of an assistant, bring the front bumper to the vehicle. Connect the two fog light harness 2-pin connectors (if equipped), then reinstall the front bumper.

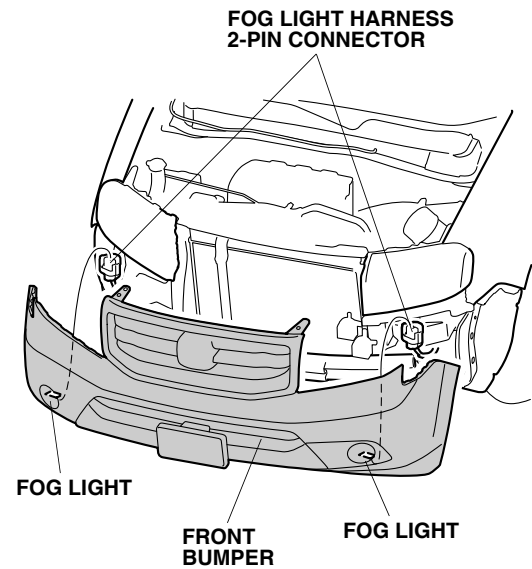

- Reinstall the splash shield, the front bulkhead cover, and the intake air box.
- Inspect the ATF fluid level and adjust as required.
- Install the hang-tag around the rearview mirror.
- Install the appropriate towing capacity label over the existing label.

